

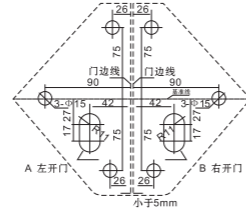

GL-017

- 材质: 304不锈钢
- 表面处理: 镜面/砂光
- 适用于厚度为8-12mm的钢化玻璃门使用

- Material: 304stainless steel
- Surface treatment: Mirror/Sanding
- Suitable for boughened glass door with a thickness of 8-12mm



GL-020

- 材质: 304不锈钢
- 表面处理: 镜面/砂光
- 适用于厚度为10-18mm的钢化玻璃门使用

- Material: 304stainless steel
- Surface treatment: Mirror/Sanding
- Suitable for boughened glass door with a thickness of 10-18mm

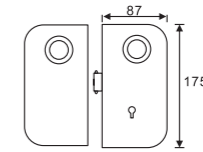

GL-018

- 材质: 304不锈钢
- 表面处理: 镜面/砂光
- 适用于厚度为8-12mm的钢化玻璃门使用

- Material: 304stainless steel
- Surface treatment: Mirror/Sanding
- Suitable for boughened glass door with a thickness of 8-12mm

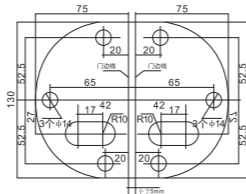

GL-021

- 材质: 304不锈钢
- 表面处理: 镜面/砂光
- 适用于厚度为10-18mm的钢化玻璃门使用

- Material: 304stainless steel
- Surface treatment: Mirror/Sanding
- Suitable for boughened glass door with a thickness of 10-18mm

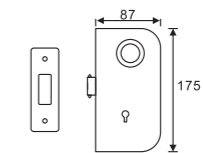

GL-019

- 材质: 锌合金
- 表面处理: 镜面/砂光
- 适用于厚度为10-18mm的钢化玻璃门使用

- Material: Zinc alloy
- Surface treatment: Mirror/Sanding
- Suitable for boughened glass door with a thickness of 10-18mm

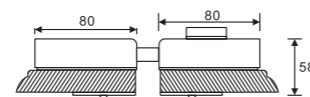

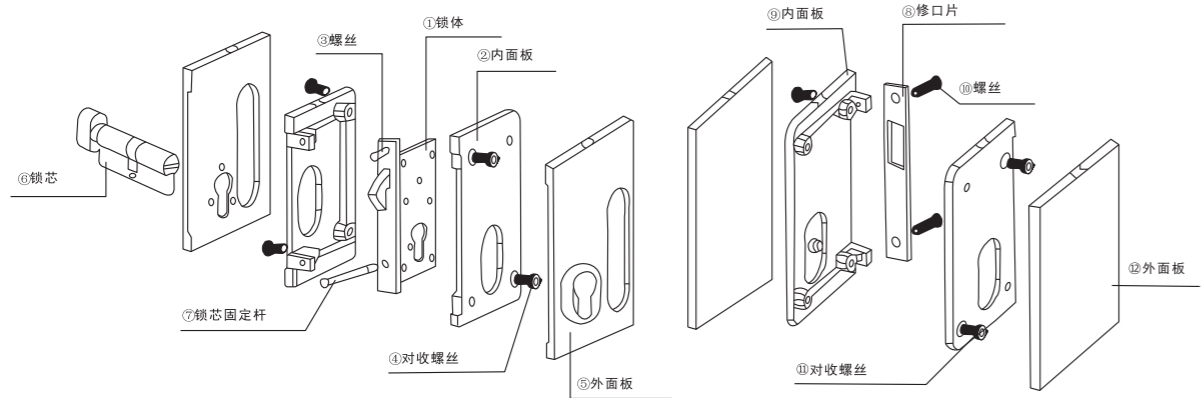

GL-024

- 材质: 锌合金+不锈钢+ABS
 - 表面处理: 镜面/砂光
 - 适用于厚度为10-18mm的钢化玻璃门使用
-
- Material: Zinc alloy + stainless steel + ABS
 - Surface treatment: Mirror/Sanding
 - Suitable for boughened glass door with a thickness of 10-18mm

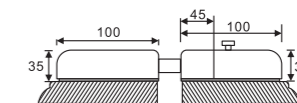

GL-022

- 材质: 304不锈钢
 - 表面处理: 镜面/砂光
 - 适用于厚度为10-18mm的钢化玻璃门使用
-
- Material: 304stainless steel
 - Surface treatment: Mirror/Sanding
 - Suitable for boughened glass door with a thickness of 10-18mm

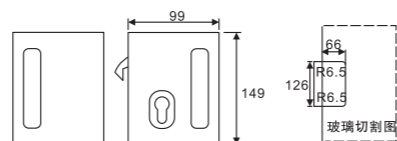

GL-023

- 材质: 304不锈钢
 - 表面处理: 镜面/砂光
 - 适用于厚度为10-18mm的钢化玻璃门使用
-
- Material: 304stainless steel
 - Surface treatment: Mirror/Sanding
 - Suitable for boughened glass door with a thickness of 10-18mm

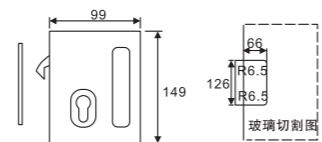



GL-025

- 材质: 304不锈钢
- 表面处理: 镜面/砂光
- 适用于厚度为10-18mm的钢化玻璃门使用

- Material: 304stainless steel
- Surface treatment: Mirror/Sanding
- Suitable for boughened glass door with a thickness of 10-18mm

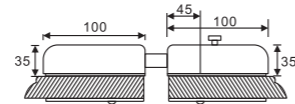

GL-026

- 材质: 304不锈钢
- 表面处理: 镜面/砂光
- 适用于厚度为10-18mm的钢化玻璃门使用

- Material: 304stainless steel
- Surface treatment: Mirror/Sanding
- Suitable for boughened glass door with a thickness of 10-18mm

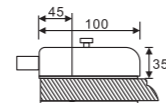

GL-027

- 材质: 铜+不锈钢
- 表面处理: 光铬
- 适用于厚度为8-12mm的钢化玻璃门使用

- Material: Copper + stainless steel
- Surface treatment: Light Chrome
- Suitable for boughened glass door with a thickness of 8-12mm

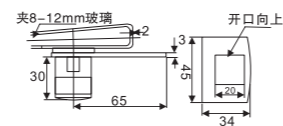

GL-028

- 材质: 铜+不锈钢
- 表面处理: 光铬
- 适用于厚度为8-12mm的钢化玻璃门使用

- Material: Copper + stainless steel
- Surface treatment: Light Chrome
- Suitable for boughened glass door with a thickness of 8-12mm

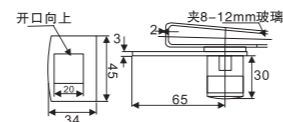

GL-029

- 材质: 铜+不锈钢
- 表面处理: 光铬
- 适用于厚度为8-12mm的钢化玻璃门使用

- Material: Copper + stainless steel
- Surface treatment: Light Chrome
- Suitable for boughened glass door with a thickness of 8-12mm

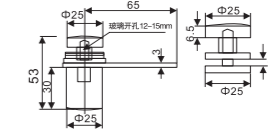

GL-030

- 材质: 铜+不锈钢
- 表面处理: 光铬
- 适用于厚度为8-12mm的钢化玻璃门使用

- Material: Copper + stainless steel
- Surface treatment: Light Chrome
- Suitable for boughened glass door with a thickness of 8-12mm

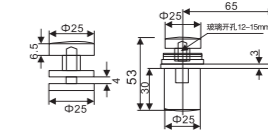

GL-031

- 材质: 铜+不锈钢
- 表面处理: 光铬
- 适用于厚度为8-12mm的钢化玻璃门使用

- Material: Copper + stainless steel
- Surface treatment: Light Chrome
- Suitable for boughened glass door with a thickness of 8-12mm

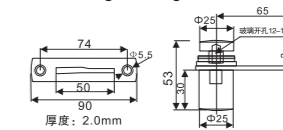

GL-032

- 材质: 铜+不锈钢
- 表面处理: 光铬
- 适用于厚度为8-12mm的钢化玻璃门使用

- Material: Copper + stainless steel
- Surface treatment: Light Chrome
- Suitable for boughened glass door with a thickness of 8-12mm

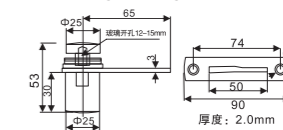



PF-001

适用门厚: 10-12mm
 表面处理: 亮光、砂光、钛金等
 主要材质: 不锈钢、铝合金
 Door thickness: 10-12mm
 Finishing: light, sanding, titanium,
 Material: stainless steel, aluminum alloy

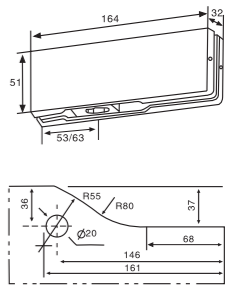

PF-002

适用门厚: 10-12mm
 表面处理: 亮光、砂光、钛金等
 主要材质: 不锈钢、铝合金
 Door thickness: 10-12mm
 Finishing: light, sanding, titanium,
 Material: stainless steel, aluminum alloy

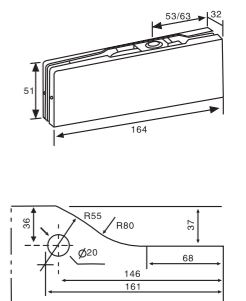

PF-003

适用门厚: 10-12mm
 表面处理: 亮光、砂光、钛金等
 主要材质: 不锈钢、铝合金
 Door thickness: 10-12mm
 Finishing: light, sanding, titanium,
 Material: stainless steel, aluminum alloy

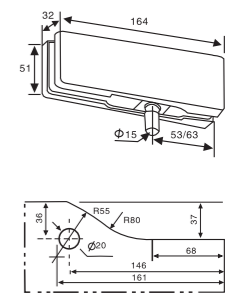

PF-004

适用门厚: 10-12mm
 表面处理: 亮光、砂光、钛金等
 主要材质: 不锈钢、铝合金
 Door thickness: 10-12mm
 Finishing: light, sanding, titanium,
 Material: stainless steel, aluminum alloy

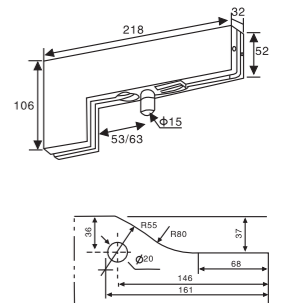

PF-005

适用门厚: 10-12mm
 表面处理: 亮光、砂光、钛金等
 主要材质: 不锈钢、铝合金
 Door thickness: 10-12mm
 Finishing: light, sanding, titanium,
 Material: stainless steel, aluminum alloy

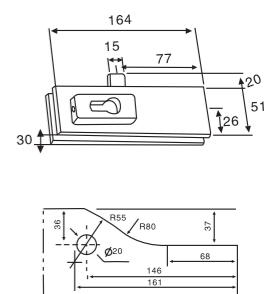



PF-007

适用门厚：10-12mm
表面处理：亮光、砂光、钛金等
主要材质：不锈钢、铝合金

Door thickness: 10-12mm
Finishing: light, sanding, titanium,
Material: stainless steel, aluminu

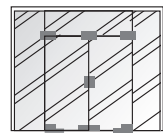
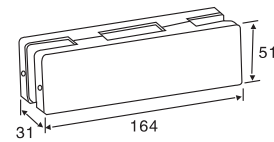

PF-008

适用门厚：10-12mm
表面处理：亮光、砂光、钛金等
主要材质：不锈钢、铝合金

Door thickness: 10-12mm
Finishing: light, sanding, titanium,
Material: stainless steel, aluminu

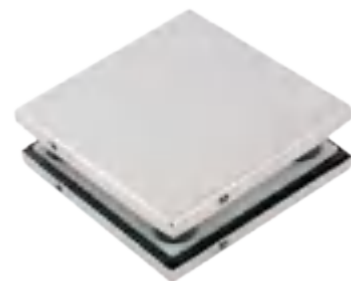
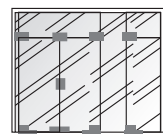
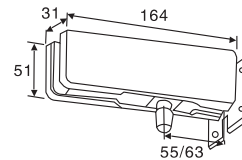

PF-009

适用门厚：10-12mm
表面处理：亮光、砂光、钛金等
主要材质：不锈钢、铝合金

Door thickness: 10-12mm
Finishing: light, sanding, titanium,
Material: stainless steel, aluminu

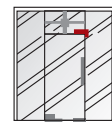
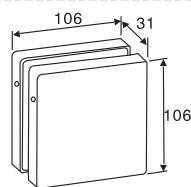

PF-011

适用门厚：10-12mm
表面处理：亮光、砂光、钛金等
主要材质：不锈钢、铝合金

Door thickness: 10-12mm
Finishing: light, sanding, titanium,
Material: stainless steel, aluminu

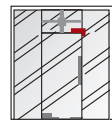
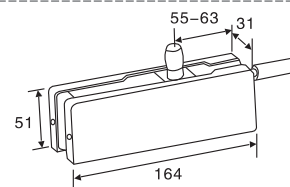

PF-012

适用门厚：10-12mm
表面处理：亮光、砂光、钛金等
主要材质：不锈钢、铝合金

Door thickness: 10-12mm
Finishing: light, sanding, titanium,
Material: stainless steel, aluminu

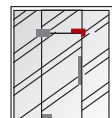
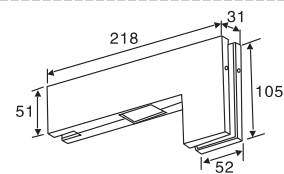

PF-013

适用门厚：10-12mm
表面处理：亮光、砂光、钛金等
主要材质：不锈钢、铝合金

Door thickness: 10-12mm
Finishing: light, sanding, titanium,
Material: stainless steel, aluminu

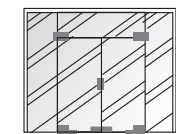
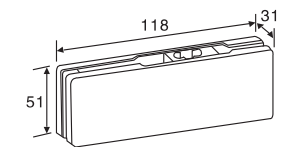

PF-014

适用门厚：10-12mm
表面处理：亮光、砂光、钛金等
主要材质：不锈钢、铝合金

Door thickness: 10-12mm
Finishing: light, sanding, titanium,
Material: stainless steel, aluminu

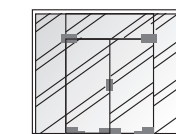
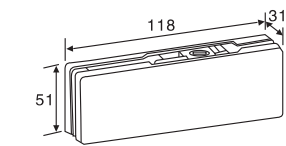

PF-015

适用门厚：10-12mm
表面处理：亮光、砂光、钛金等
主要材质：不锈钢、铝合金

Door thickness: 10-12mm
Finishing: light, sanding, titanium,
Material: stainless steel, aluminu

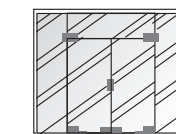
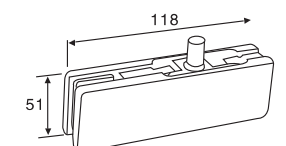

PF-016

适用门厚：10-12mm
表面处理：亮光、砂光、钛金等
主要材质：不锈钢、铝合金

Door thickness: 10-12mm
Finishing: light, sanding, titanium,
Material: stainless steel, aluminu

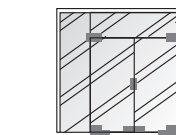
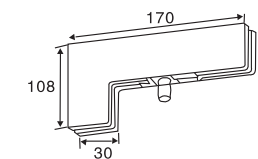

PF-017

适用门厚：10-12mm
表面处理：亮光、砂光、钛金等
主要材质：不锈钢、铝合金

Door thickness: 10-12mm
Finishing: light, sanding, titanium,
Material: stainless steel, aluminu

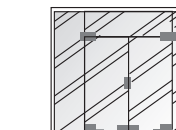
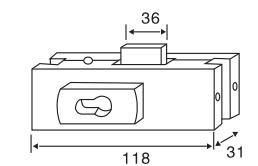



PF-018

适用门厚: 10-12mm
 表面处理: 亮光、砂光、钛金等
 主要材质: 不锈钢、铝合金
 Door thickness: 10-12mm
 Finishing: light, sanding, titanium,
 Material: stainless steel, aluminu

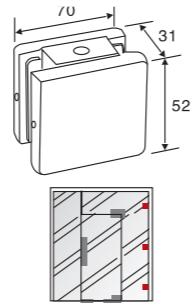

PF-019

适用门厚: 10-12mm
 表面处理: 亮光、砂光、钛金等
 主要材质: 不锈钢、铝合金
 Door thickness: 10-12mm
 Finishing: light, sanding, titanium,
 Material: stainless steel, aluminu

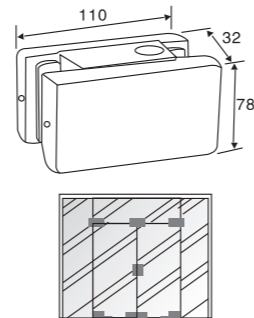

PF-020

适用门厚: 10-12mm
 表面处理: 亮光、砂光、钛金等
 主要材质: 不锈钢、铝合金
 Door thickness: 10-12mm
 Finishing: light, sanding, titanium,
 Material: stainless steel, aluminu

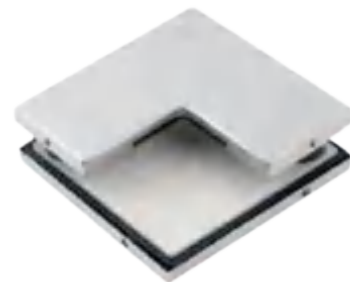
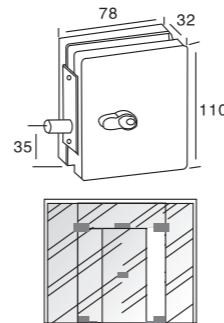

PF-021

适用门厚: 10-12mm
 表面处理: 亮光、砂光、钛金等
 主要材质: 不锈钢、铝合金
 Door thickness: 10-12mm
 Finishing: light, sanding, titanium,
 Material: stainless steel, aluminu

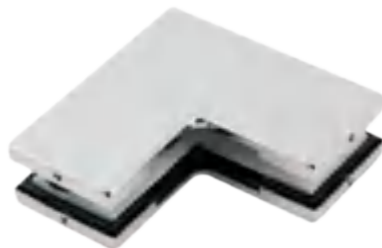
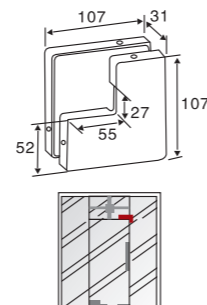

PF-022

适用门厚: 10-12mm
 表面处理: 亮光、砂光、钛金等
 主要材质: 不锈钢、铝合金
 Door thickness: 10-12mm
 Finishing: light, sanding, titanium,
 Material: stainless steel, aluminu

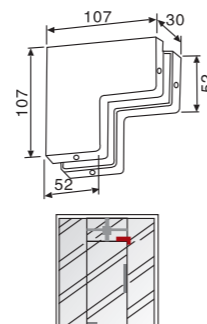

PF-888



- 适合门重: ≤120
- 适合门宽: 750-1100mm
- 适合门厚: 8-13mm
- 使用环境温度: -30℃~+50℃
- 关速平稳顺畅
符合中国GA标准

使用性能

- 0° 门扇关闭
- 90° 可定位
- 0° ~90° 可自动复位至0°
- 关门为二段调速:
90° ~20° 为第一段
20° ~0° 为第二段

PF-888 技术参考资料

适用门宽	750~1100mm
适用门重	≤100kg
主体尺寸(mm)	长: 200 高: 70 宽: 40
最大开启门角度	130°
关门速度调整	√
缓冲速度调整	√
防爆装置	√
定位装置	√
定位装置 (在90° 定位)	√
左右边门共用	√
保证期限	开合40万次
√=标准装置	

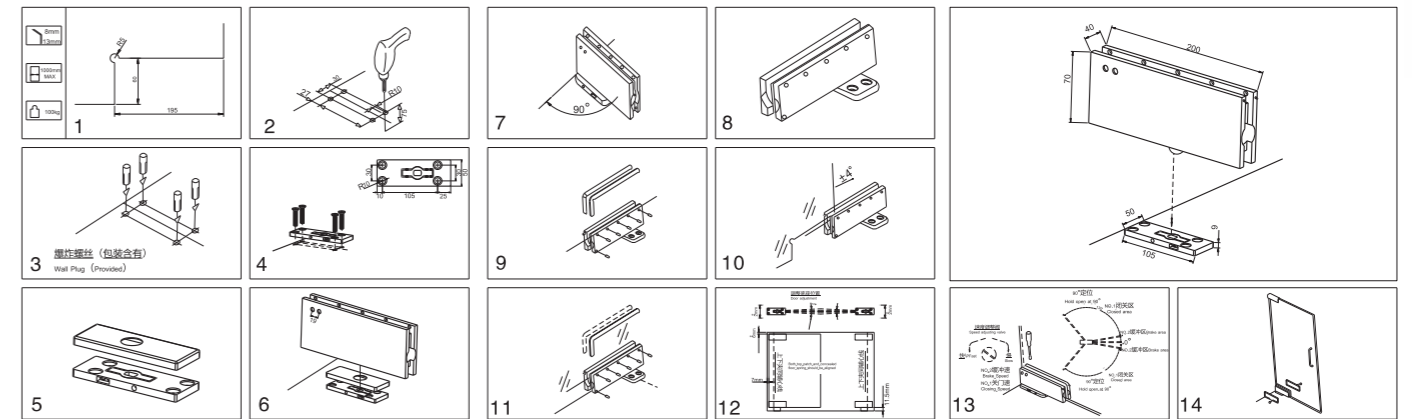

MW-ZT004

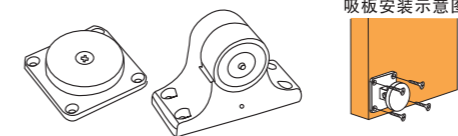

MW-ZT005

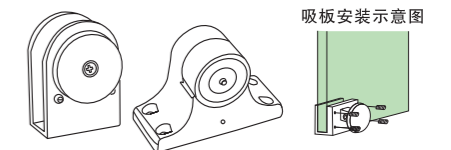

型号	安全类型	输入电压/工作电流	吸合力	手动释放	LED指示	电压误差范围	环境温度	相对湿度	锁体尺寸	适用门型	适用玻璃厚度
MW-ZT004	断电释放	DC12V/150mA DC24V/80mA	23Kg (50Lbs)	√	√	±15%	-25° C~55° C	不大于28%	110*80*83	木门、有框门	—
MW-ZT005	断电释放	DC12V/150mA DC24V/80mA	23Kg (50Lbs)	√	√	±15%	-25° C~55° C	不大于28%	110*80*83	无框玻璃门	12~15mm, 19mm



材质：精铸不锈钢、锌合金、黄铜
Material: stainless steel, zinc alloy, brass

表面处理：镜光、拉丝
Surface treatment: mirror light, drawing

适合门宽：800-1000mm
Suitable for door width: 800-1000mm

适合门厚：8-12mm
Suitable for door thickness: 8-12mm

适合范围：钢化玻璃门
Suit scope: toughened glass door

GC-018A 方形0° 固定浴室玻璃夹
Square 0 degree fixed bathroom glass clamp



GC-018B 方形90° 固定浴室玻璃夹
Square 90 degree fixed bathroom glass clamp



GC-019 方形90° 单边浴室玻璃夹
Square 90 degree single side bathroom glass clamp

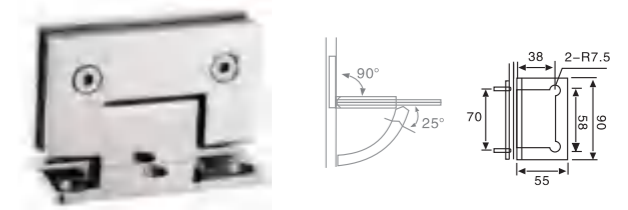

GC-020 方形90° 双边浴室玻璃夹
Square 90 degree double bathroom glass clamp

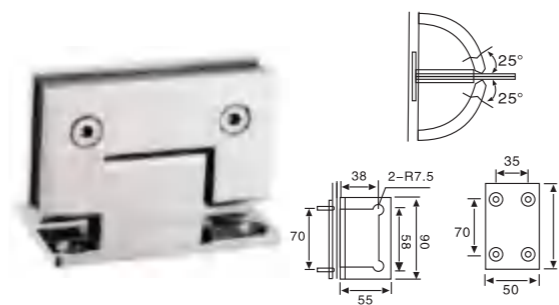

GC-021 方形90° 双开浴室玻璃夹
90 degree square double bathroom glass clamp

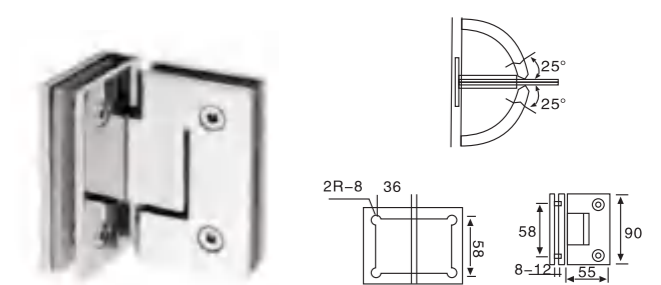

GC-022 方形135° 浴室玻璃夹
Square 135 degree bathroom glass clamp

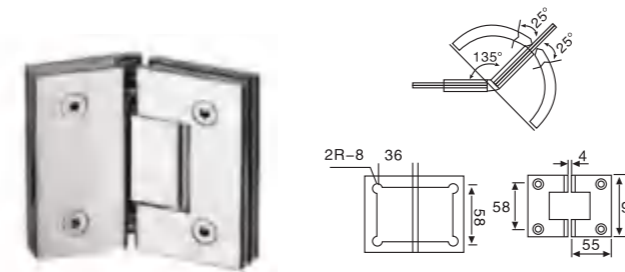

GC-024 方形180° 浴室玻璃夹
Square 180 degree bathroom glass clamp

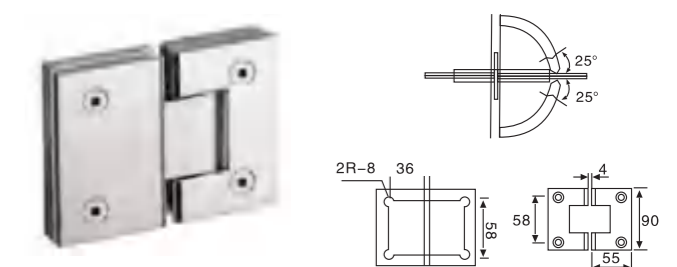

材质：精铸不锈钢、锌合金、黄铜
Material: stainless steel, zinc alloy, brass

表面处理：镜光、拉丝
Surface treatment: mirror light, drawing

适合范围：钢化玻璃门
Suit scope: toughened glass door

适合门厚：8-12mm
Suitable for door thickness: 8-12mm

适合门宽：800-1000mm
Suitable for door width: 800-1000mm

材质：精铸不锈钢、锌合金、黄铜
Material: stainless steel, zinc alloy, brass

表面处理：镜光、拉丝
Surface treatment: mirror light, drawing

适合门宽：800-1000mm
Suitable for door width: 800-1000mm

适合门厚：8-12mm
Suitable for door thickness: 8-12mm

适合范围：钢化玻璃门
Suit scope: toughened glass door

GC-015长形90° 单边双开浴室玻璃夹 Long 90° Unilateral Double Open Bathroom Glass Clip

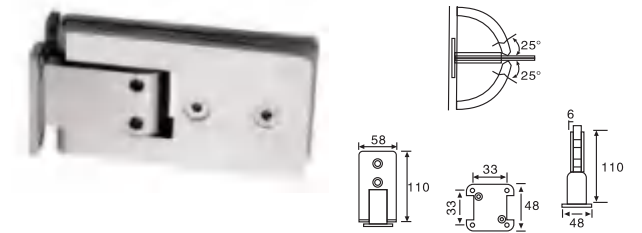

GC-025A斜边圆角0° 浴室玻璃夹 Round 0 degrees bevel bathroom glass clamp

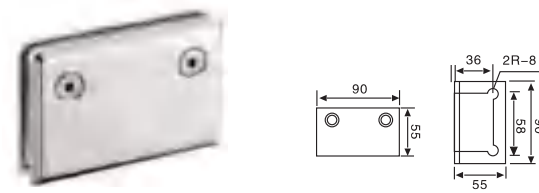

GC-025B斜边圆角90° 固定浴室玻璃夹 Bevel Fillet 90° Fixed Bathroom Glass Clip

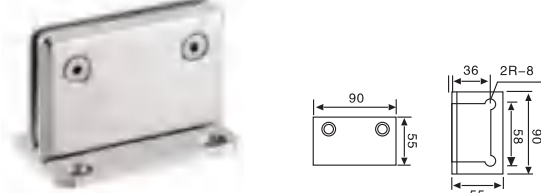

GC-016 长形135° 浴室玻璃夹 Long 135 degree bathroom glass clamp

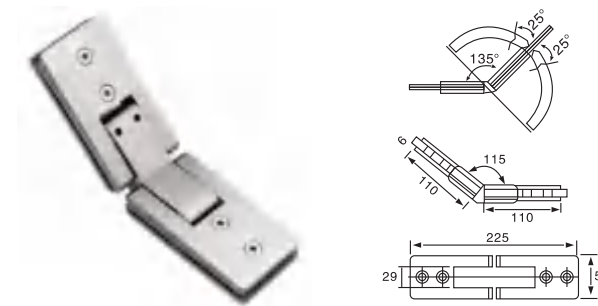

GC-017 长形180° 浴室玻璃夹 Long 180 degree bathroom glass clamp

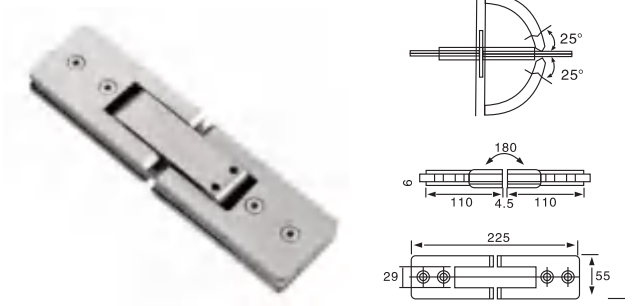

GC-025C斜边圆角360° 浴室玻璃夹 Round 360 degrees bevel bathroom glass clamp



GC-026 斜边圆角90° 单边浴室玻璃夹 Beveled Corner 90° Unilateral Bathroom Glass Clip

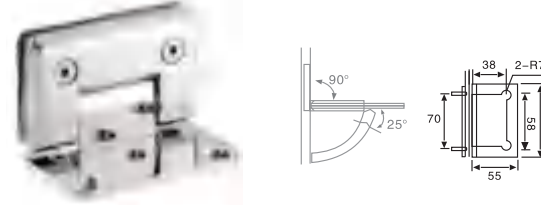

GC-035 弧形90° 单边浴室玻璃夹 Curved 90 degree single side bathroom glass clamp



GC-036 弧形90° 双边浴室玻璃夹 Arc 90 degree double bathroom glass clamp

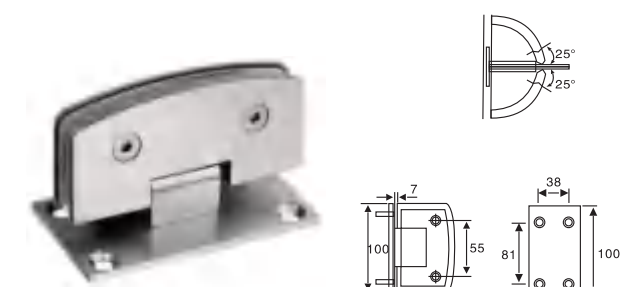

GC-027 斜边圆角90° 双边浴室玻璃夹 Round 90 degrees bevel bilateral bathroom glass clamp

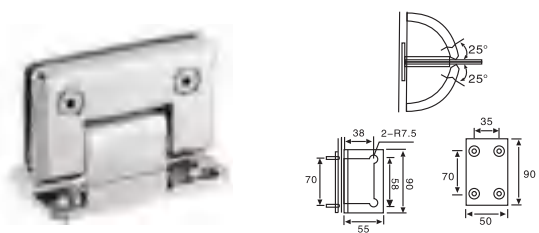

GC-028 斜边圆角90° 双页浴室玻璃夹 Bevel Fillet 90° Double Page Bathroom Glass Clip

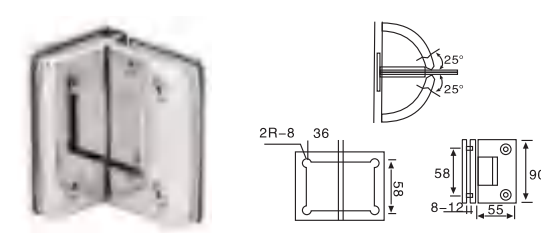

GC-037 弧形135° 浴室玻璃夹 Arc 135 degree bathroom glass clamp

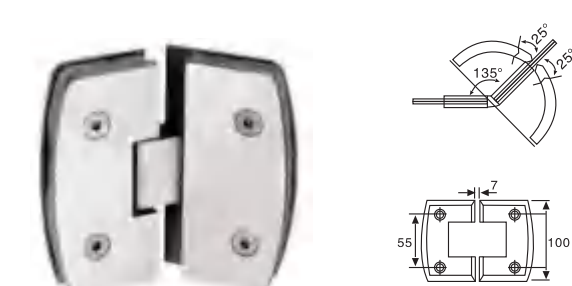

GC-038 弧形180° 浴室玻璃夹 Arc 180 degree bathroom glass clamp

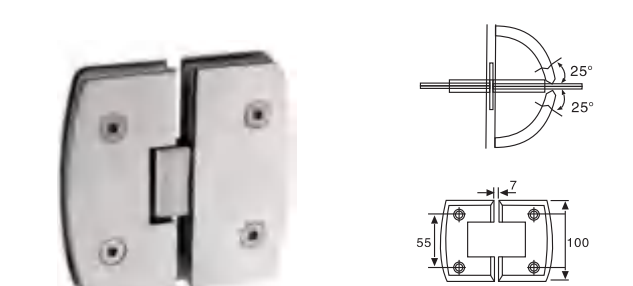

GC-029 斜边圆角135° 浴室玻璃夹 Round 135 degrees bevel bathroom glass clamp

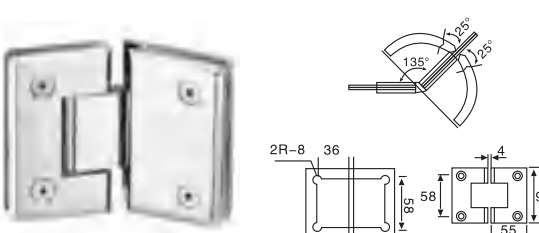

GC-030 斜边圆角180° 浴室玻璃夹 Bevel Fillet 180° Bathroom Glass Clip

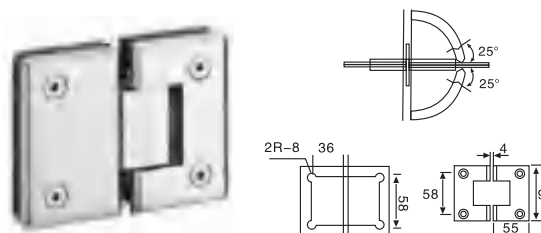

材质：精铸不锈钢、锌合金、黄铜
Material: stainless steel, zinc alloy, brass

表面处理：镜光、拉丝
Surface treatment: mirror light, drawing

适合范围：钢化玻璃门
Suit scope: toughened glass door

适合门厚：8-12mm
Suitable for door thickness: 8-12mm

适合门宽：800-1000mm
Suitable for door width: 800-1000mm

GC-044 半圆长形90° 双开浴室玻璃夹
Semi-circular 90° Double Open Bathroom Glass Clip

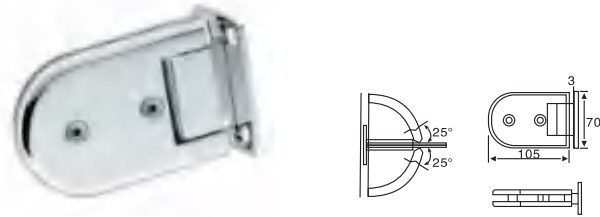

GC-045 半圆长形90° 双页浴室玻璃夹
A long 90 degree double page bathroom glass clamp



GC-046 半圆长形135° 浴室玻璃夹
A long 135 degree bathroom glass clamp

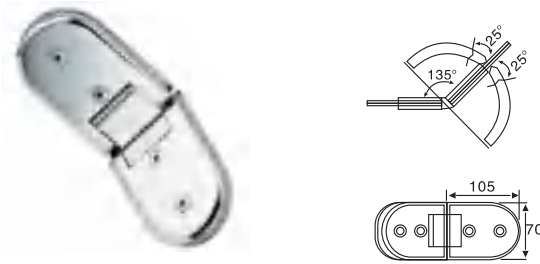

GC-047 半圆长形180° 浴室玻璃夹
A long 180 degree bathroom glass clamp



GC-001 方形固定夹0°
Square fixing clip 0°

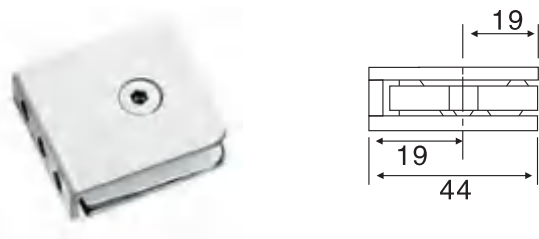

GC-002 方形固定夹90° 双面
Square fixing clip 90° Double

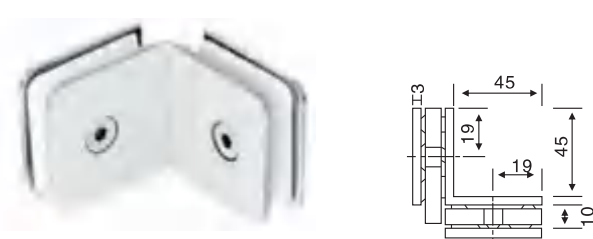

GC-003 方形固定夹135° 双面
Square fixing clip 135° Double

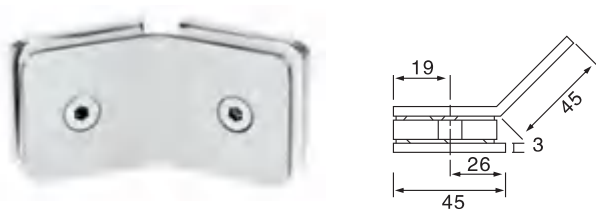

GC-004 方形固定夹180° 单面
Square fixing clip 180° Single

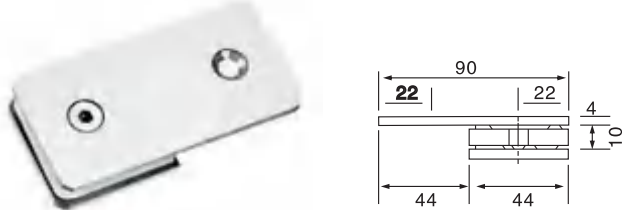

材质：精铸不锈钢、锌合金、黄铜
Material: stainless steel, zinc alloy, brass

表面处理：镜光、拉丝
Surface treatment: mirror light, drawing

适合范围：钢化玻璃门
Suit scope: toughened glass door

适合门厚：8-12mm
Suitable for door thickness: 8-12mm

适合门宽：800-1000mm
Suitable for door width: 800-1000mm

GC-001R 玻璃椭圆隔断码0°
Glass ellipse partition 0°



GC-002R 玻璃椭圆隔断码90° 双面
Glass ellipse partition 90° Double



GC-003R 玻璃椭圆隔断码135° 单面
Glass elliptical partition code 135° Single



GC-004 玻璃椭圆隔断码180° 双面
Glass elliptical partition code 180° Double

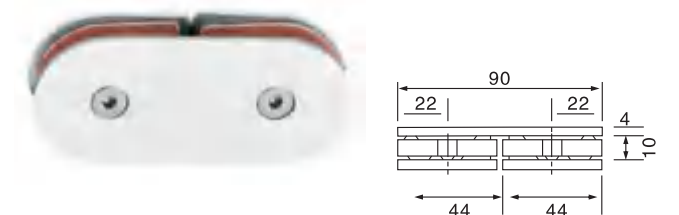

GC-008B 方形固定夹0°
Square fixing clip 0°

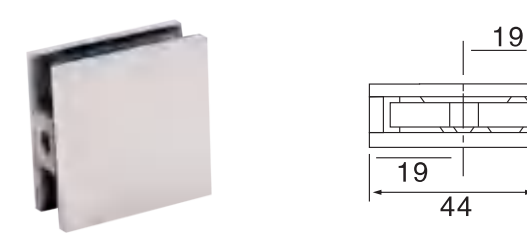

GC-009 方形固定夹90° 单面
Square fixing clip 90° Single

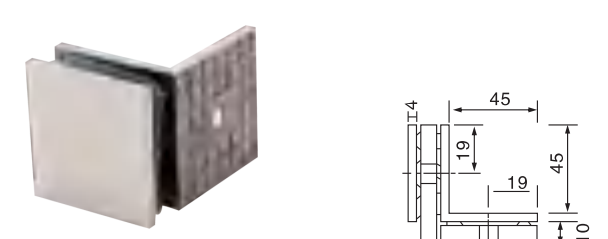

GC-010 方形固定夹135° 双面
Square fixing clip 135° Double



GC-011 方形固定夹180° 双面
Square fixing clip 180° Double

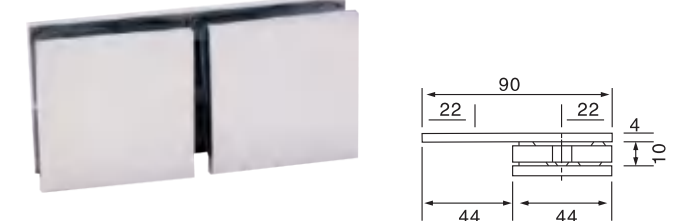

GDH-001

材质: 不锈钢
表面处理: 镜光、拉丝

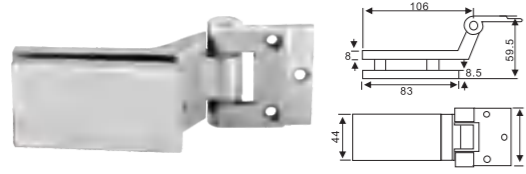

GDH-002

材质: 不锈钢
表面处理: 镜光、拉丝

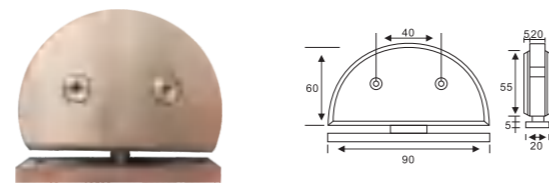

GDH-003

材质: 不锈钢
表面处理: 镜光、拉丝

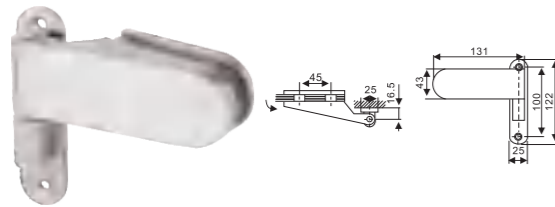

GDH-004

材质: 不锈钢
表面处理: 镜光、拉丝

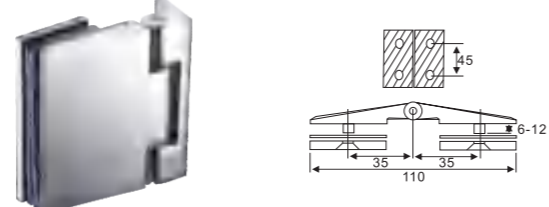

GDH-005

材质: 不锈钢
表面处理: 镜光、拉丝

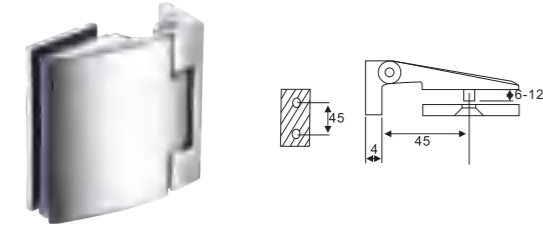

GDH-006

材质: 不锈钢
表面处理: 镜光、拉丝

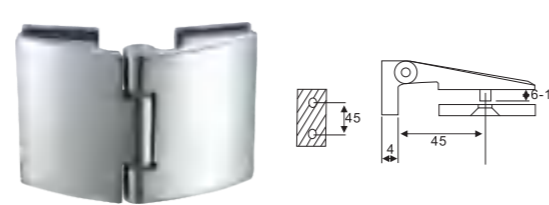

GDH-007

材质: 不锈钢
表面处理: 镜光、拉丝

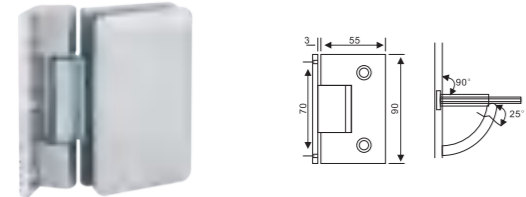

GDH-008

材质: 不锈钢
表面处理: 镜光、拉丝

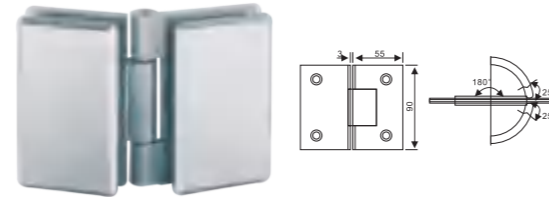

GDH-009

材质: 不锈钢
表面处理: 镜光、拉丝

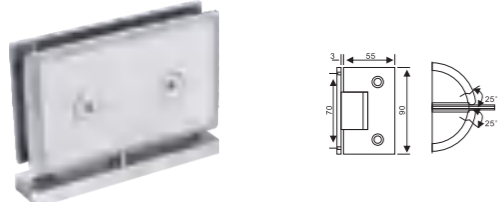

GDH-010

材质: 不锈钢
表面处理: 镜光、拉丝

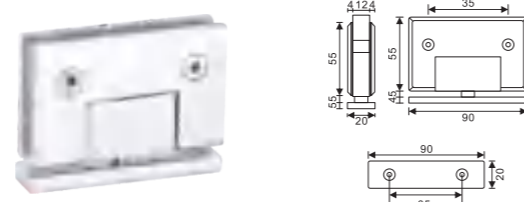

GDH-011

材质: 不锈钢
表面处理: 镜光、拉丝



GDH-012

材质: 不锈钢
表面处理: 镜光、拉丝



GDH-013

材质: 不锈钢
表面处理: 镜光、拉丝

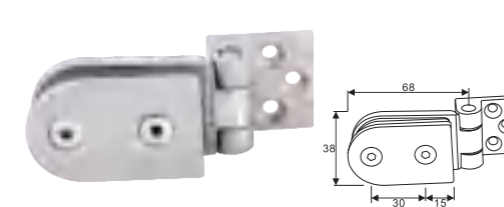

GDH-014

材质: 不锈钢
表面处理: 镜光、拉丝



GDH-015

材质: 不锈钢
表面处理: 镜光、拉丝

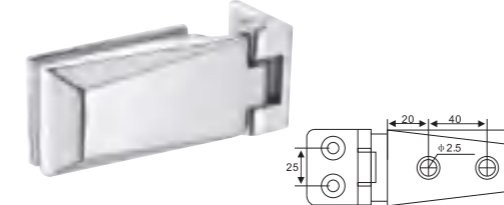

GDH-016

材质: 不锈钢
表面处理: 镜光、拉丝

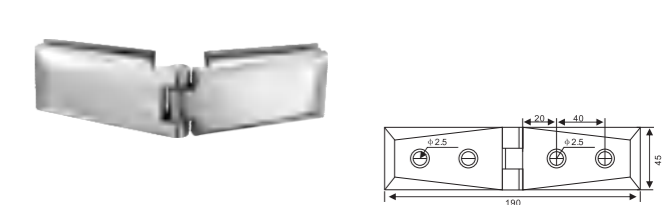

GDH-017

材质: 不锈钢
表面处理: 镜光、拉丝

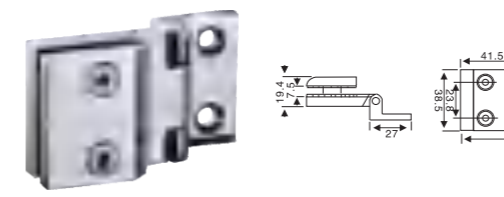

GDH-018

材质: 不锈钢
表面处理: 镜光、拉丝

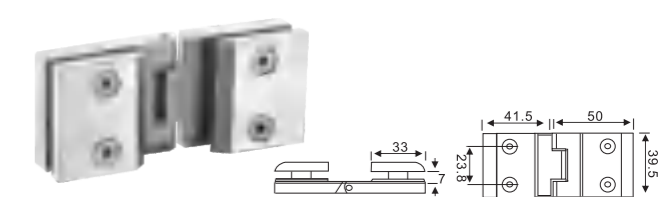

GDH-019

材质: 不锈钢
表面处理: 镜光、拉丝

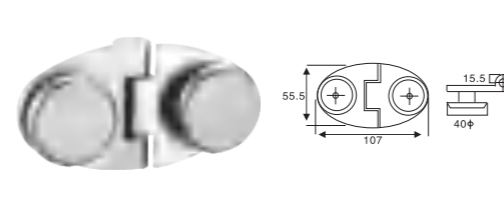

GDH-020

材质: 不锈钢
表面处理: 镜光、拉丝

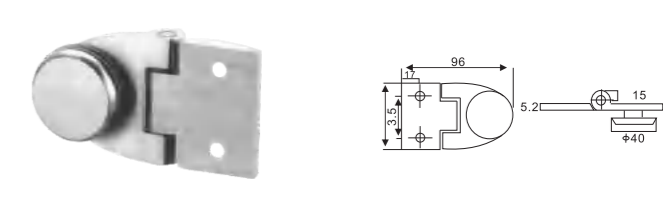

GDH-021

材质: 不锈钢
表面处理: 镜光、拉丝

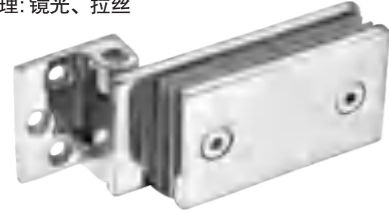

GDH-022

材质: 不锈钢
表面处理: 镜光、拉丝



GDH-023

材质: 不锈钢
表面处理: 镜光、拉丝

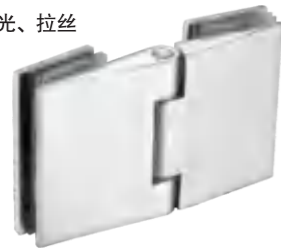

GDH-024

材质: 不锈钢
表面处理: 镜光、拉丝



GDH-025

材质: 不锈钢
表面处理: 镜光、拉丝



GDH-026

材质: 不锈钢
表面处理: 镜光、拉丝

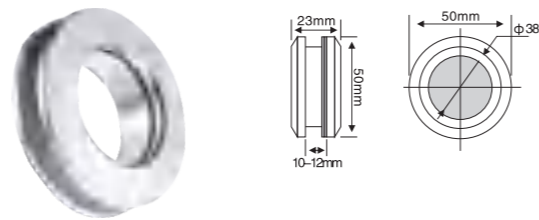

GDH-027

材质: 不锈钢
表面处理: 镜光、拉丝

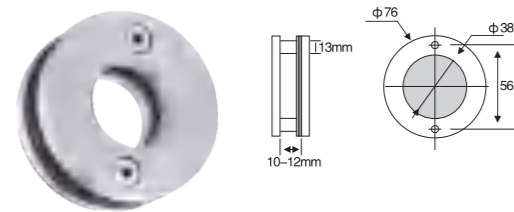

GDH-028

材质: 不锈钢
表面处理: 镜光、拉丝

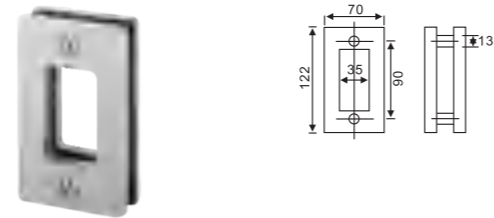

GDH-029

材质: 不锈钢
表面处理: 镜光、拉丝

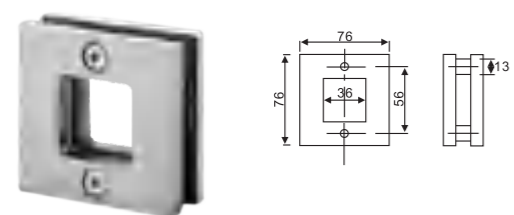

GDH-030

材质: 不锈钢
表面处理: 镜光、拉丝

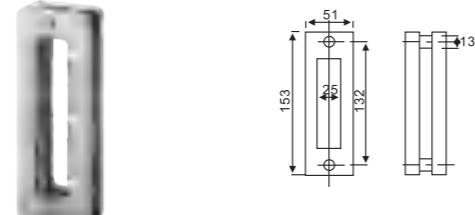

SHOWER ROOM ACCESSORIES

整体淋浴房配件

GDH-031

材质: 不锈钢
表面处理: 镜光、拉丝



GDH-032

材质: 不锈钢
表面处理: 镜光、拉丝



GDH-033

材质: 不锈钢
表面处理: 镜光、拉丝



GDH-034

材质: 不锈钢
表面处理: 镜光、拉丝



GDH-035

材质: 不锈钢
表面处理: 镜光、拉丝



GDH-036

材质: 不锈钢
表面处理: 镜光、拉丝



GDH-037

材质: 不锈钢
表面处理: 镜光、拉丝



GDH-038

材质: 不锈钢
表面处理: 镜光、拉丝



GDH-039

材质: 不锈钢
表面处理: 镜光、拉丝



GDH-040

材质: 不锈钢
表面处理: 镜光、拉丝



GH-001A

材质: 不锈钢、铜、铝
Material: stainless steel, copper, aluminum
表面处理: 亮光、拉丝
Surface treatment: light, drawing

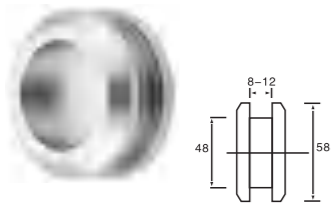

GH-001B

材质: 不锈钢、铜、铝
Material: stainless steel, copper, aluminum
表面处理: 亮光、拉丝
Surface treatment: light, drawing

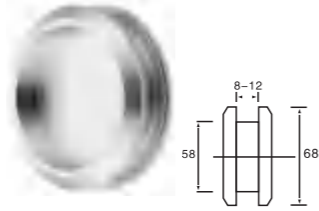

GH-001C

材质: 不锈钢 (冲压)
Material: stainless steel
表面处理: 亮光、拉丝
Surface treatment: light, drawing

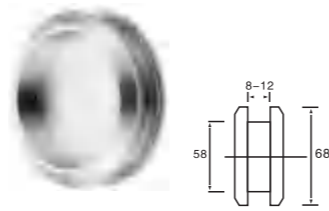

GH-002

材质: 不锈钢、铜、铝
Material: stainless steel, copper, aluminum
表面处理: 亮光、拉丝
Surface treatment: light, drawing

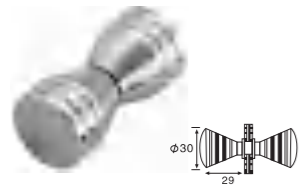

GH-003

材质: 不锈钢、铜、铝
Material: stainless steel, copper, aluminum
表面处理: 亮光、拉丝
Surface treatment: light, drawing

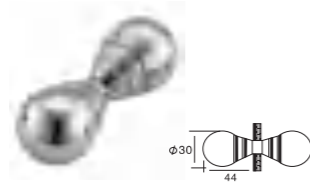

GH-004

材质: 不锈钢、铜、铝
Material: stainless steel, copper, aluminum
表面处理: 亮光、拉丝
Surface treatment: light, drawing

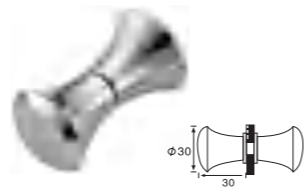

GH-005

材质: 不锈钢、铜、铝
Material: stainless steel, copper, aluminum
表面处理: 亮光、拉丝
Surface treatment: light, drawing

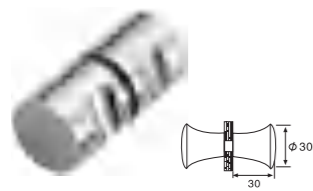

GH-006

材质: 不锈钢、铜、铝
Material: stainless steel, copper, aluminum
表面处理: 亮光、拉丝
Surface treatment: light, drawing

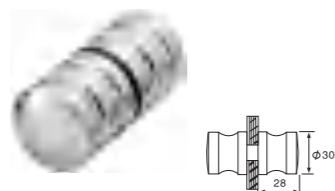

GH-007

材质: 不锈钢、铜、铝
Material: stainless steel, copper, aluminum
表面处理: 亮光、拉丝
Surface treatment: light, drawing

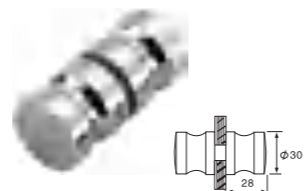

GH-008

材质: 不锈钢、铜、铝
Material: stainless steel, copper, aluminum
表面处理: 亮光、拉丝
Surface treatment: light, drawing

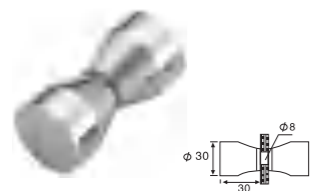

GH-009

材质: 不锈钢、铜、铝
Material: stainless steel, copper, aluminum
表面处理: 亮光、拉丝
Surface treatment: light, drawing

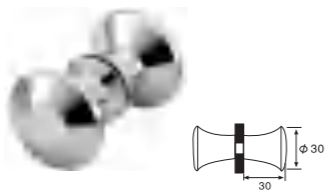

GH-010

材质: 不锈钢、铜、铝
Material: stainless steel, copper, aluminum
表面处理: 亮光、拉丝
Surface treatment: light, drawing



BCB-01

材质: 不锈钢、黄铜
表面处理: 砂光、镜光



BCB-02

材质: 不锈钢、黄铜
表面处理: 砂光、镜光

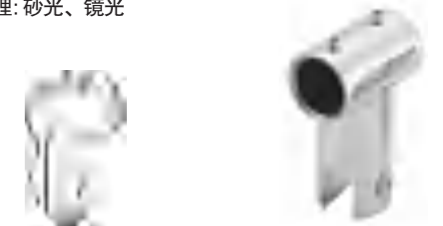

BCB-03

材质: 不锈钢、黄铜
表面处理: 砂光、镜光



BCB-05

材质: 不锈钢、黄铜
表面处理: 砂光、镜光



BCB-06

材质: 不锈钢、黄铜
表面处理: 砂光、镜光



BCB-07

材质: 不锈钢、黄铜
表面处理: 砂光、镜光



BCB-08

材质: 不锈钢、黄铜
表面处理: 砂光、镜光



BCB-10

材质: 不锈钢、黄铜
表面处理: 砂光、镜光

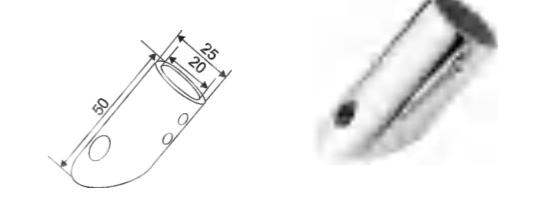

BCB-11

材质: 不锈钢、黄铜
表面处理: 砂光、镜光

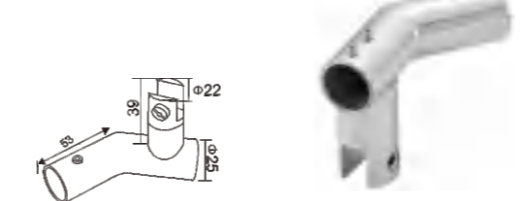

BCB-12

材质: 不锈钢、黄铜
表面处理: 砂光、镜光

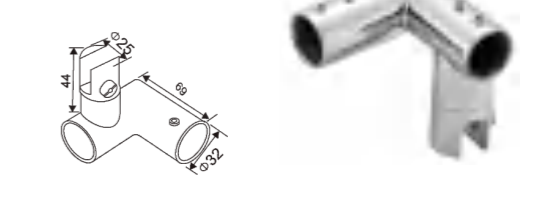

FS-220B

材质：铁
表面处理：砂光、镜光

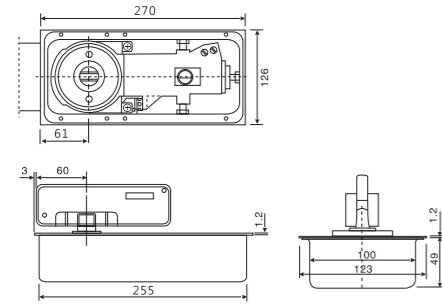

功能特性 Function characteristic	最大开启角度 Maximum opening angle	适用门扇尺寸 Max Door Leaf Size	外观尺寸 Dimension	适用门重 Door Weight
技术参数 Technical Parameter	110°	800x2000mm	270x126x49mm	80kg

FS-818

材质：铁
表面处理：砂光、镜光

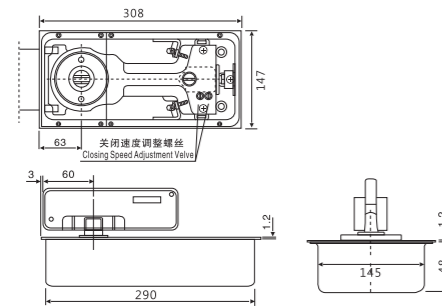

功能特性 Function characteristic	最大开启角度 Maximum opening angle	适用门扇尺寸 Max Door Leaf Size	外观尺寸 Dimension	适用门重 Door Weight
技术参数 Technical Parameter	120°	1000x2000mm	380x147x48mm	90kg

FS-68

材质：铁
表面处理：砂光、镜光

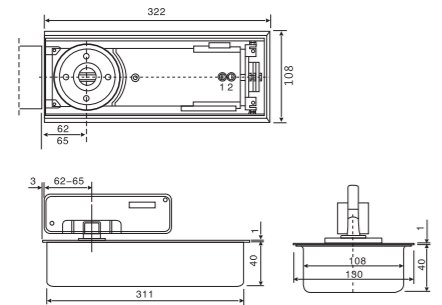

功能特性 Function characteristic	最大开启角度 Maximum opening angle	适用门扇尺寸 Max Door Leaf Size	外观尺寸 Dimension	适用门重 Door Weight
技术参数 Technical Parameter	130°	1000x2200mm	322x108x40mm	100kg

FS-65

材质：铁
表面处理：砂光、镜光

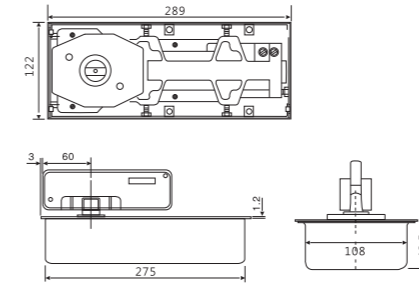

功能特性 Function characteristic	最大开启角度 Maximum opening angle	适用门扇尺寸 Max Door Leaf Size	外观尺寸 Dimension	适用门重 Door Weight
技术参数 Technical Parameter	130°	1000x2100mm	289x122x40mm	100kg

FS-7300

材质：铁
表面处理：砂光、镜光

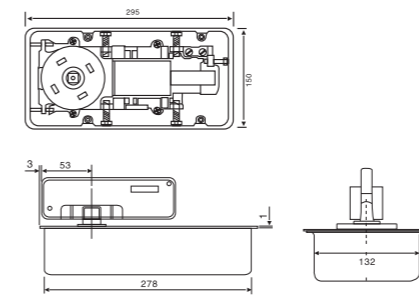

功能特性 Function characteristic	最大开启角度 Maximum opening angle	适用门扇尺寸 Max Door Leaf Size	外观尺寸 Dimension	适用门重 Door Weight
技术参数 Technical Parameter	90° 110° -180° 随意定位	1000x2100mm	295x150x40mm	100kg

FS-7300R/L

材质：铁
表面处理：砂光、镜光

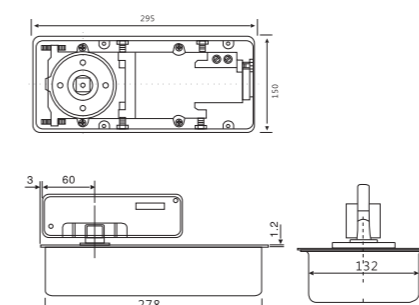

功能特性 Function characteristic	最大开启角度 Maximum opening angle	适用门扇尺寸 Max Door Leaf Size	外观尺寸 Dimension	适用门重 Door Weight
技术参数 Technical Parameter	90° 110° -180° 随意定位	1200x2200mm	295x150x65mm	120kg



GL-001

材质：不锈钢
表面处理：砂光、镜光

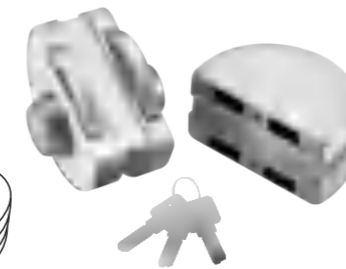
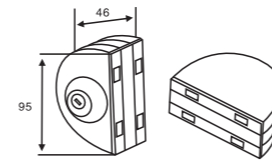

GL-002

材质：不锈钢
表面处理：砂光、镜光

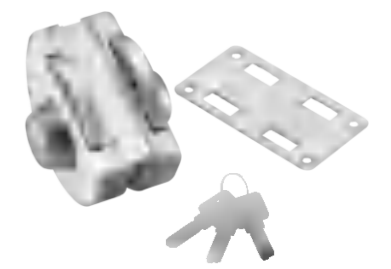
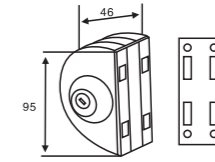

GL-003

材质：不锈钢
表面处理：砂光、镜光

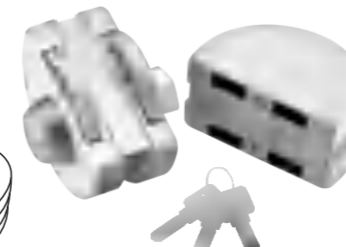
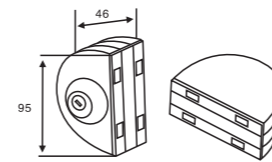

GL-004

材质：不锈钢
表面处理：砂光、镜光

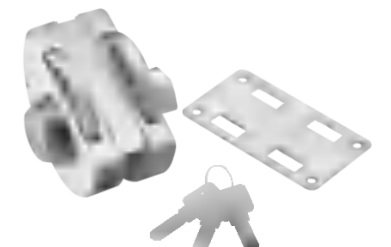
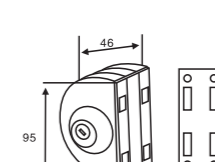

GL-005

材质：不锈钢
表面处理：砂光、镜光

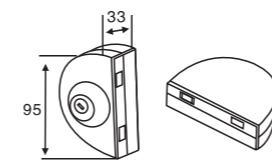

GL-006

材质：不锈钢
表面处理：砂光、镜光

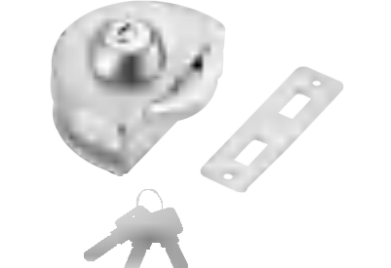
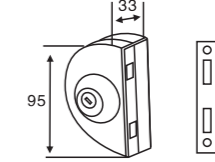

GL-007

材质：不锈钢
表面处理：砂光、镜光

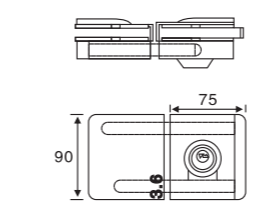

GL-008

材质：不锈钢
表面处理：砂光、镜光

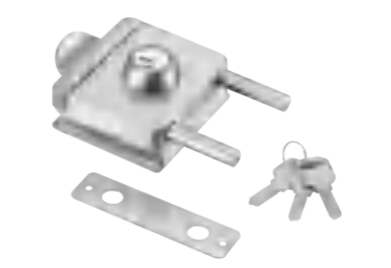
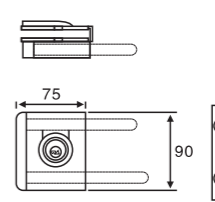

GL-009

材质：不锈钢
表面处理：砂光、镜光

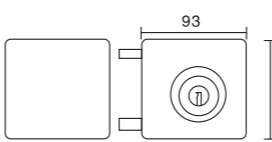

GL-010

材质：不锈钢
表面处理：砂光、镜光

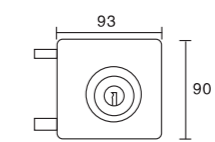

Model: 1300 	Model: 1301 	Model: 1302 	Model: 1303 
Model: 1304 	Model: 1305 	Model: 1306 	Model: 1307 
Model: 1308 	Model: 1309 	Model: 1310 	Model: 1311 
Model: 1312 	Model: 1313 	Model: 1314 	Model: 1315 
Model: 1316 	Model: 1317 	Model: 1318 	Model: 1319 
Model: 1320 	Model: 1321 	Model: 1322 	Model: 1323 

Model: 1324 	Model: 1325 	Model: 1326 	Model: 1327 
Model: 1328 	Model: 1329 	Model: 1330 	Model: 1331 
Model: 1332 	Model: 1333 	Model: 1334 	Model: 1335 
Model: 1336 	Model: 1337 	Model: 1338 	Model: 1339 
Model: 1340 	Model: 1341 	Model: 1342 	Model: 1343 
Model: 1344 	Model: 1345 	Model: 1346 	Model: 1347 

<p>Model: 1350</p> 	<p>Model: 1351</p> 	<p>Model: 1352</p> 	<p>Model: 1353</p> 
<p>Model: 1354</p> 	<p>Model: 1355</p> 	<p>Model: 1356</p> 	<p>Model: 1357</p> 
<p>Model: 1358</p> 	<p>Model: 1359</p> 	<p>Model: 1360</p> 	<p>Model: 1361</p> 
<p>Model: 1362</p> 	<p>Model: 1363</p> 	<p>Model: 1364</p> 	<p>Model: 1365</p> 
<p>Model: 1366</p> 	<p>Model: 1367</p> 	<p>Model: 1368</p> 	<p>Model: 1369</p> 
<p>Model: 1370</p> 	<p>Model: 1371</p> 	<p>Model: 1372</p> 	<p>Model: 1373</p> 

